

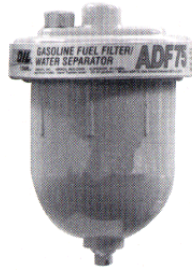

ADF75 COMPACT FILTER/SEPARATOR



ADF75

Gasoline or Diesel Fuel
Filter/Water Separator
U.L. Listed and U.S. Coast Guard
Accepted for Marine Applications

Flow Rates

- **ADF75:**
Recommended:20 GPH (U.S.) (75.7 LPH)
Maximum:30 GPH (U.S.) (113.5 LPH)

Specifications

- **Flow Resistance:**0.75 in. Mercury @ 20 GPH
- **Maximum Working Pressure:**25 PSI (172 kPa)
- **Temperature Range:**.....-50° to +225°F (-45 to +107C)
- **Port Thread:**.....9/16-18 w/O-Ring Boss
- **Height**6 1/8 in. (155.6 mm)
- **Width:**4 3/16 in. (106.4 mm)
- **Depth:**4 3/4 in. (120.6 mm)
- **Element Removal Clearance:**3 1/2 in. (88.9 mm)
- **Sump Capacity:**4 oz. (118 ml)

Accessories

All Inlet & Outlet Fittings Require O-Ring Seals
Fittings.....See AMSOIL/DAHL Fittings Chart

Mounting Hole Pattern

Clearance for 5/16 in.
Diameter Fasteners

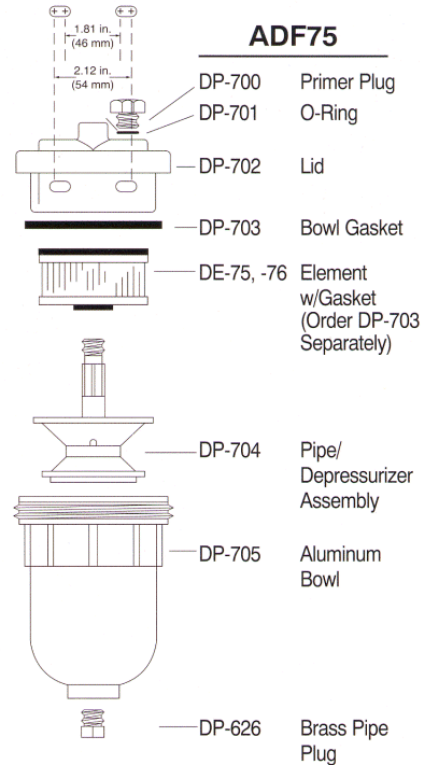

Service Parts

- **Elements:**
DE-75*2 Micron Element
DE-7610 Micron Element
Recommended Service Interval:250 hours
or 10,000 miles
- **Gaskets:**
DP-375.....Complete Gasket Kit for ADF75

* Standard with Unit